

HNP023 Series Oil Purifier

For fluid viscosities up to 700 cSt



MEHNP023ENC

Water in hydraulic, lubrication, power transmission and insulating fluids adversely affects fluid performance and is a threat to system reliability.

Water contamination promotes corrosion and fluid system component wear, resulting in reduced component life and increased maintenance costs. It also degrades fluid properties, leading to reduced lubricity and load carrying ability, oil oxidation and the resultant formation of acids, and additive precipitation. The consequences are reduced fluid service life and increased fluid procurement and disposal costs.

Description

The Pall HNP023 Series Oil purifier is designed for use with small to medium oil systems, and can effectively remove 26 liters of water per day from the oil*.

The Pall HNP fluid conditioning purifier uses vacuum dehydration to remove 100 % free water and as much as 90 % of dissolved water. It will also remove 100 % of free and entrained gases and up to 80 % dissolved gases. Vacuum dehydration is the most effective method of water removal at minimum cost and ease of use. Unlike other methods it removes both free and dissolved water and cannot burn or otherwise significantly alter the properties of the oil.

Particulate contaminant removal is achieved using high performance rated ($\beta_{3(c)} > 2000$) Athalon® filter elements.

In addition, a WS12 Series water sensor measures water content and temperature at the purifier inlet, allowing the purifier to operate only when the water content rises above a pre-determined level.

**Water removal rates are affected by the fluid viscosity, temperature, form of water (free or dissolved) and the amount of water present. Pall utilizes a well defined and repeatable test procedure that ensures thorough dispersion of the water in the test fluid initially and throughout the test. The water removal rate shown is for tests with ISO VG 32 mineral based turbine lube oil at 60 °C in the range of 2.6 % to 1.4 % water. The removal rates at higher water concentrations will be significantly higher.*



HNP023 Series Oil Purifier

Select the HNP023 oil purifier for:

- High performance water, gas and particulate removal
- Extension of fluid service life
- Minimized corrosion within systems
- Reduced fluid disposal
- Reduced operating costs
- Increased equipment reliability
- Simple automated operation
- Remote monitoring option

Removing free water is never enough!

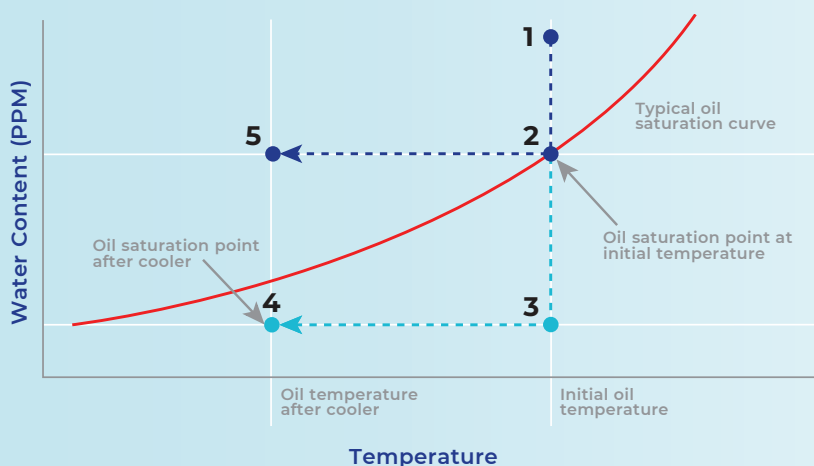

- 1 Initial water content is above saturation (free water).
- 2 Maximum water removal capability of 'free water removal' devices (coalescers, centrifuges, etc.) is to the oil's saturation point.
- 3 Water content achieved with vacuum dehydration is significantly below the oil's saturation point.
- 4 Water content achieved with vacuum dehydration remains below the oil's saturation point even after oil is cooled by the system heat exchanger. This prevents the formation of free water which is detrimental to fluid system components and the fluid.
- 5 If only free water is removed at initial temperature, when oil is cooled the amount of free water in the oil can increase significantly.

Specifications

Flow Rate:	20 LPM @50Hz (25 LPM @60Hz)
Dimensions:	1348 mm x 578 mm x 1504 mm
Dry mass:	250 kg (551 lb)
Inlet/Outlet connections:	See table 3 below
Water removal rate*:	26 L/day (6.8 US gpd)
Inlet pressure:	1.5 barg (21.8 psi g) maximum
System back pressure:	4.6 barg (66.7 psi g) maximum
Fluid temperature:	+10 °C (50 °F) to +70 °C (158 °F)
Fluid viscosity:	700 cSt maximum
Operating vacuum:	-0.6 bar g (18" Hg) to -0.9 bar g (27" Hg) [adjustable]
Power supply:	See Table 1
Total Motor power:	2.22 kW maximum

Materials of Construction

Base frame:	Carbon Steel, painted
Vessel:	304 Stainless steel
Hydraulic fittings:	Zinc plated carbon steel
Control box:	Carbon steel, painted
Hydraulic hoses and seals:	Fluorocarbon

NOTE: Pall fluid conditioning purifiers comply with all applicable EC directives and bears the CE mark.

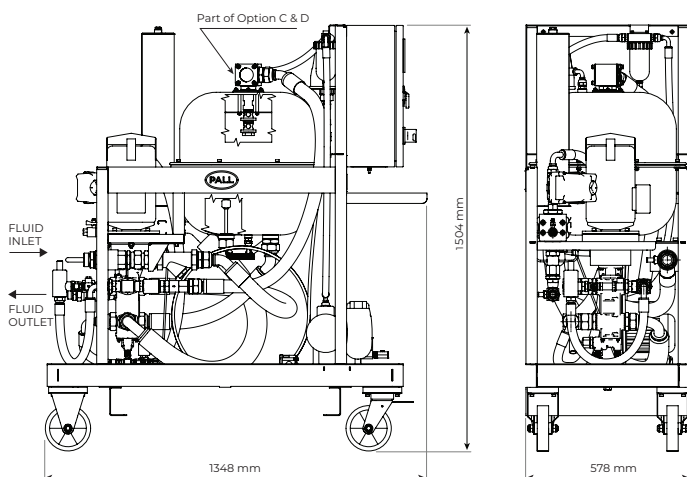

Ordering Information

Purifier						
P/N: HNP023	1	1	Z	2	3	4
	Code 1	Code 2				

Note: Z indicates fluorocarbon seals and chlorinated polyethylene hoses are standard. Other options are available; contact Pall.

Please select only from the following list of standard purifier options:

HNP023S3ZCPENA	HNP023S3ZCPFRA
HNP023S3ZCPENB	HNP023S3ZCPFRC
HNP023S3ZCPEND	HNP023S3ZCPFRD
HNP023S3ZCPDEA	HNP023S3ZCPI TB
HNP023S3ZCPDEB	HNP023T3ZCPENA
HNP023S3ZCPDED	HNP023T3ZCPENB

Table 1 - Standard Voltage/Frequency Options

Code 1	Voltage	Code 2	Frequency	Control Voltage
S	400 Vac	3	50 Hz, 3Ø	24 Vdc
T	415 Vac	3	50 Hz, 3Ø	24 Vdc
U	440 Vac	4	60 Hz, 3Ø	24 Vdc

Standard voltages only listed. Other voltages will be available on request - price and lead time will be provided on application.

Table 2 - Mounting Options

Code	Mounting Type
C	Castor - Ø6", 2 x fixed / 2 x swivel

Table 3 - Process Port Connection Options

Code	Type	Inlet	Outlet
P	Parallel	G1 ½ male to ISO228 c/w bonded seal surface	G1 male to ISO228 c/w bonded seal surface

Table 4 - Language Options

Code	Language
DE	German
EN	English
FR	French
IT	Italian

Table 5 - Optional Factory Fitted Kits

Code	Kit
A	No optional kit(s) fitted
B	5m electrical cable, socket and plug, in accordance with IEC 60309
C	Gauge points, inlet and outlet pressure gauges and an inlet sight flow indicator
D	Both kits B and C

Replacement filter element P/N: UE310**20Z (Beta_{X(C)} >2000)

where ** = AZ, (3µm), AP (5µm), AN (7µm), AS (12µm) or AT (22µm).

Replacement Air Breather P/N: HC0293SEES



Corporate Headquarters
Port Washington, NY, USA
+1-800-717-7255 toll free (USA)
+1-516-484-5400 phone

European Headquarters
Fribourg, Switzerland
+41 (0)26 350 53 00 phone

Asia-Pacific Headquarters
Singapore
+65 6389 6500 phone

Visit us on the Web at www.pall.com/industry
Contact us at www.pall.com/contact

Pall Corporation has offices and plants throughout the world. To locate the Pall office or distributor nearest you, visit www.pall.com/contact.

The information provided in this literature was reviewed for accuracy at the time of publication. Product data may be subject to change without notice. For current information consult your local Pall distributor or contact Pall directly.

IF APPLICABLE Please contact Pall Corporation to verify that the product conforms to your national legislation and/or regional regulatory requirements for water and food contact use.

© Copyright 2022, Pall Corporation. Pall, and Athalon are trademarks of Pall Corporation. ® Indicates a trademark registered in the USA.

MEHNP023ENC
Sept 2022