



Pall Corporation

LP00962

Installation and Operating Instructions

SUPRApak™ M Series SA and WA Systems

service instructions



EN Installation and Operating Instructions
SUPRApak™ M Series SA and WA Systems

ENGLISH

These instructions are valid for SUPRApak Filter Units with model numbers:

SPMWA100***	SPMWA200***	SPMWA210***	SPMWA300***
SPMWA311***	SPMWA320***	SPMWA400***	SPMWA421***
SPMSA100***	SPMSA200***	SPMSA210***	SPMSA300***
SPMSA311***	SPMSA320***	SPMSA400***	SPMSA421***

FBSPAKMEN

Table of Contents

1 Safety

1.1	About this Chapter	4
1.2	Safety Warnings	4
1.2.1	Hazard Classification	4
1.3	Potential Safety Hazards	4
1.4	Hazard Sources	4
1.5	Proper Use	5
1.5.1	Potential Explosive Atmosphere – ATEX	5
1.6	Prohibition of Unauthorized Modifications	5
1.7	Personnel Training	5
1.7.1	Target Group	5
1.7.2	Authorized Personnel	5
1.8	Operating Log	6
1.9	Safety and Protection Devices	6
1.9.1	Safety Check	6
1.10	Protective Equipment	6
1.11	Safety during Operation	6
1.12	Safety during Maintenance	7
1.12.1	Maintenance Work	7
1.12.2	Accident Report	7
1.13	Chemical Substances	7
1.14	Fire	7
1.15	Remaining Hazards	7

2 General Information

2.1	Identification	8
2.2	Operating Data, Connections, Measurements and Weights	8
2.3	Footprint and Operator's Position	8

3 Assembly and Function

3.1	About this Chapter	8
3.2	General View	9
3.3	Operating Data – Housing	9
3.4	Safety Warnings – Pressure Vessel	9
3.5	Safety Valve	9
3.6	Vent units	9
3.7	Drain valves	9
3.8	Isolation valves	9
3.9	Non-return valve	9
3.10	Functional description	9

4 Installation

4.1	About this Chapter	10
4.2	Delivery and Storage	10
4.3	Transport	10
4.3.1	Information about the transport of the SUPRApak Filter Unit	10
4.4	Unpacking, Cleaning and Installation	10
4.4.1	Requirements for the Installation Location	10
4.4.2	Unpacking	10
4.4.3	Installation	10
4.4.4	Cleaning of New Units	10
4.5	Safety Warnings – Pressure Vessel	11

4.6	Assembly/disassembly instructions filter unit and accessories	11
4.6.1	Opening and lifting of the filter housing	11
4.6.2	Equipping the filter with SUPRApak modules	11
4.6.3	Positioning of the dome and closing of the filter housing	12
4.6.4	SUPRApak filter unit with standard accessories	13
4.7	Connecting	13
4.7.1	Compressed air, inert gas	13
4.7.2	Rinsing liquid	13
4.7.3	Hot water sanitization	13
4.8	Lifting device for SUPRApak modules	13

5 Operation and Process Description

5.1	About this Chapter	15
5.2	Prior to Commissioning	15
5.3	During Operation	15
5.3.1	Safety	15
5.4	Initial Commissioning / Test Run	15
5.4.1	Test Run	15
5.4.2	Controls prior to the Test Run	15
5.5	Filtration	16
5.5.1	Pre-rinsing	16
5.5.1.1	When should pre-rinsing be carried out?	16
5.5.1.2	Which medium is recommended for pre-rinsing?	16
5.5.1.3	Process description for pre-rinsing	16
5.5.2	Hot Water Sanitization	16
5.5.2.1	When should sanitization be done?	16
5.5.2.2	What medium should be used for sanitization?	16
5.5.2.3	Process description for hot water sanitization	16
5.5.3	Filling with Product and Filtering	16
5.5.3.1	Filling	16
5.5.3.2	Pressurization	16
5.5.4	Rinsing after Filtration	16
5.5.4.1	When should rinsing be done?	16
5.5.4.2	Process description for rinsing	17
5.5.5	Emptying	17
5.5.5.1	Emptying without pressure	17
5.5.5.2	Emptying after pre-rinsing	17
5.5.5.3	Displacement with pressurized gas	17
5.6	Use of SUPRApak modules at higher temperatures or increased viscosity applications	17
5.6.1	Use at filtration temperature > 40 °C	17
5.6.2	Rinsing before filtration at T > 40 °C	18
5.6.3	Interrupting the filtration at T > 40 °C	18
5.7	Cleaning the Housing	18
5.8	Disposal	18
6	Service	
6.1	About this Chapter	18
6.2	Safety	18
6.2.1	Preparation	19
6.2.2	Returning to Operation	19

6.3	Inspection and Maintenance	19
6.3.1	Demounting/Mounting of Clamping Device and Exchange of Lip Seal	19
6.4	Repair	20
6.5	Failure	21
6.5.1	Causes of failure and their elimination	21
7	Appendix	
7.1	Warranty	21
7.2	Product Observation	21
7.3	Spare Parts	22
8	Explosion Protection (ATEX)	
8.1	General	22
8.2	Marking	22
8.3	Process Description/Indication for a Safe Operation	22
8.3.1	Filling	22
8.3.2	Filtering	23
8.3.3	Discharging the Filtrate	23
8.3.4	Cleaning	23
8.3.5	Mounting and Dismounting or Exchange of the Modules	23
8.3.6	Putting into Operation after Standstill	23
8.4	Information for Safe Intended Use	23
8.5	Information for Safe Mounting/Dismounting	24
8.6	Information for Safe Maintenance	24
8.7	Information for Safe Installation	24
8.8	Information for Dangerous Areas	24
8.9	Information for Safe Operative Range	24
8.10	Information about Safe Operating Data, Limiting Values, Surface Temperature	24
8.11	Information about Special Conditions for Use	24

1 Safety

1.1 About this Chapter

This part of the operating instructions

- refers to the correct use of the filter unit
- explains the meaning and use of the warning signs listed on the following pages
- points out the hazards that might result from non-observance of these operating instructions
- informs the user how to avoid hazards.

In addition to these operating instructions, general requirements as well as all further regulations regarding health protection and accident prevention must be observed. Personnel must be trained on the proper use of the filter unit.

Safety and danger signs displayed on the filter unit must be observed.

The technical documentation must always be kept close to the filter unit.



Information

In case of any occurring problems that cannot be solved by means of the Pall documentation please do not hesitate to contact:

Pall Corporation

www.pall.com

To contact a Pall Sales Office or Distributor, go to:

<http://www.pall.com/contact> for specific local contact information.

For any inquiries, please make use of the "Product Observation" form, which is part of the Appendix (= Chapter 7.3 Product Observation).

We will be glad to assist you.

1.2 Safety Warnings

1.2.1 Hazard Classification

The individual safety warnings are subdivided according to their meaning and significance. The following chart gives the user a view concerning the hazard symbols (pictograms) used, their meaning (signal words) and a description of the concrete hazards with their potential consequences.

Pictogram	Damage for	Signal word	Definition	Consequences
	Persons	Danger	Immediate danger	Death or serious injuries (causing disability)
		Warning	Possible dangerous situation	Possibility of death or serious injuries (causing disability)
		Caution	Less dangerous situation	Possibility of minor or slight injuries
	Objects	Attention	Possible damage	Possible damage to <ul style="list-style-type: none"> • the product • its surroundings
	-	Information	Application advice and further useful information	No dangerous or damaging consequences for persons or objects

1.3 Potential Safety Hazards

The filter unit has undergone hazard analysis.

Construction and design of the filter unit complies with the current applicable state of the art.



DANGER!

Prior to the first operation the operator must:

- install any necessary safety and protection devices in order to safeguard the operator or the filter unit from any sources of danger
- establish and supervise an effective job safety program for the filter unit
- introduce and supervise a necessary maintenance program for the filter unit.



DANGER!

It is absolutely imperative to make sure that the filter housing is in a depressurized state before the clamping ring (V-band) is opened.

Prior to pressurization of the filter housing, it is absolutely imperative to make sure that the filter housing is closed (V-band) and all couplings are connected.

In case of wrong operation or improper use there is danger to:

- personnel (including bodily injury or death) (i.e. due to poisoning, chemical burns, explosion, etc.)
- the unit and further material assets of the operating company
- the efficient work of the plant

Each person dealing with mounting, commissioning, operating and maintenance must:

- provide the necessary professional qualifications
- strictly observe these operating instructions

1.4 Hazard Sources

The filter unit operates with

- filtration products
- chemical substances (for cleaning purposes)
- liquids and gases under pressure with higher temperatures



WARNING!

These sources of danger might

- endanger personnel with bodily injury or death
- endanger personnel health
- damage the filter unit and further material assets of the operating company
- reduce the efficiency of the plant

Ensure that the filter unit is always depressurized and that it cannot inadvertently become pressurized with liquids or gases via the equipment connections, prior to:

- maintenance work
- correction of defects in safety and protection devices

The removal and shutdown of safety devices during operation of the unit is absolutely prohibited!

1.5 Proper Use

The filter unit must be operated with properly functioning safety devices and properly installed protection devices! The filter unit must be shut down immediately in case of malfunctioning or ineffectiveness of a safety or protection device.

Operator and operating company are both responsible for correct use!

Should any hazards occur during the filtration process, especially when

- handling harmful substances and materials
 - integrating the filter unit into an existing total unit
- the operating company must effectively safeguard personnel and equipment from the hazard sources in compliance with the locally prevailing regulations, laws and allowed limits.

The filter unit must be used exclusively to filter liquid products (suspensions), in accordance with the design classification.

The operating personnel must be given adequate handling and operating instructions.

Any application which exceeds or is not in conformance with the order details will be regarded as an improper use and thus Pall Corporation will not be held responsible for any occurrences.

The materials of construction, mainly stainless steel, are also resistant to most cleaning and disinfecting agents used. The operator is in charge of testing the susceptibility of the equipment to corrosion.

The maximum operating temperature and maximum design pressure (⇒ Chapter 2.2 Operating Data, Connections, Measurements and Weights) must not be



CAUTION!

Should the filter unit be used for any other purpose than mentioned above, or should the intended capacity or process limits be exceeded, the filter unit is in danger of being damaged or even destroyed. Pall Corporation will not be held responsible or liable for damages that can be attributed to improper handling and operation; the user will be solely responsible. Under these circumstances, the warranty will no longer be valid.

exceeded.

The strict observance of the operating instructions as well as the adherence to inspection and maintenance conditions are imperative conditions for a proper use of the filter unit.

1.5.1 Potentially Explosive Atmosphere – ATEX

The filtration unit has been designed for use in normal atmosphere conditions.

For use of the filter unit in potentially explosive atmosphere, the additional Chapter for ATEX should be observed. (⇒ Chapter 8 Explosion Protection ATEX)

1.6 Prohibition of Unauthorized Modifications

Any modification to the product not officially approved in writing by Pall Corporation shall be considered as not authorized, therefore not permitted.

Prior to any modification Pall must be contacted for approval, and failure to do so will invalidate the warranty.



WARNING!

Modifications of the filter unit or welding at load-bearing parts of the filter housing and surrounding components which are not previously agreed upon with Pall Corporation may

- harm personnel
- lead to damage or destruction of the filter unit.

1.7 Personnel Training

1.7.1 Target Group

This manual is for

- the operating company
- operators and
- service and maintenance personnel.

Therefore, all safety warnings and signs refer to operation and application of the filter unit as well as to maintenance work.

In order to avoid unauthorized use of the filter unit when it is not in operation, all feed and discharge pipes must be safeguarded at all times.

The responsibilities for the individual fields of activity (operation, set up, maintenance and repair) must be clearly defined and observed. In order to guarantee clarity of responsibilities and roles, we recommend that the responsible personnel be recorded in the operation log. (⇒ Chapter 1.8 Operating Log)

Unclear designation of personnel responsibilities represents a security risk!

1.7.2 Authorized Personnel



Information

Knowledge of the information described herein is an indispensable condition for any handling of the filter unit!



WARNING!

There is a risk of danger for personnel, material assets and environment in case of improper operation and maintenance of the filter unit!

Only authorized personnel are allowed to handle the filter unit!

Authorized personnel for operation and maintenance are the trained and skilled experts of the operating company and the manufacturer.

The operating company is responsible for

- personnel training
- personnel instruction regarding the potential hazards that may occur in the course of their activities as well as the measures to avoid such hazards; such training should be repeated at regular intervals
- documenting the trainings/instructions and confirming individual employee participation in writing
- monitoring whether personnel observe the safety procedures and the operating instructions and whether they are aware of the possible hazards.

Prior to commissioning the operator must

- have read and understood the complete operating instructions
- be familiar with all safety and protection devices as well as the safety regulations.

For work involving the following parts of the filter unit additional requirements apply:

- Electrical installations and machinery:
 - Work must be carried out only by an electrician or under the direction and supervision of an electrician
- Pneumatics:
 - Work must be carried out only by skilled persons with specific knowledge and experience with pneumatics

1.8 Operating Log

The operating log contains details concerning authorized personnel and their training and education.

The operating company is obliged to keep an operating log.

In addition to dates and names the operating log must indicate the following details:

- Occurring troubles, problems, failures and the measures that have been taken for their elimination
- Operating company-designated security checks (check list)
- Inspection, maintenance and repair work
- Updates of these operating instructions, modifications of the unit
- The "Product Observation" form



Information

The operating log must be checked at regular intervals (e.g. monthly) by responsible management personnel.

1.9 Safety and Protection Devices

The following safety devices must be part of the filter unit:

- safety valve (Feed fluid inlet ⇒ Chapter 5, Fig. 5-1 P&ID SUPRApak)

Filter unit with clamp ring (V-band):

- slide bar lock at the arm of the clamp ring (⇒ Fig. 1-2, white arrow)

Location of the safety and protection device:



Fig 1-2: Slide bar lock



WARNING!

Equipment delivered without safety relief valve: It is the operating company's responsibility to ensure the equipment is protected with an adequately rated safety relief valve in line with the operating conditions, and according to the requirements of local pressure vessel directives.

The filter unit must only be operated with properly functioning safety devices and properly installed protection devices!

The filter unit must be shut down immediately in case of malfunctioning or ineffectiveness of a safety or protection device!

Both operator and operating company are responsible for the safe condition of the filter unit!

Should a safety device be activated the filter unit may not be restarted unless

- the cause of the fault has been eliminated
- the responsible person has convinced himself that there is no more danger of bodily harm or potential for damage of material assets!

Safety devices must not be

- removed
- blocked or
- deactivated in any other way.



WARNING!

You expose yourself and everybody else in the vicinity of the equipment to potential severe injuries if you bridge or remove safety and protection devices.

Should any hazardous areas which are not sufficiently secured result from:

- the local situation, e.g. in the course of maintenance work
- or the conditions at the place of installation these areas must be secured immediately through measures that are effective at any time.

Safety measures must always be adjusted to the local working conditions and the areas which are possibly affected by the filter unit. If a safety relief valve is part of the scope of supply, it has already been adjusted to the correct pressure by the supplier. Do not readjust the setting of this safety valve without contacting Pall Corporation.

1.9.1 Safety Check

Please check the filter unit at least once per shift for externally discernible damage and defects. Any observed changes (including a change of the operating behavior) must be reported immediately to the responsible service technician.

Check all safety and protection devices (pressure test in an adequate manner)

- at the beginning of each shift (in case of interrupted operation)
- once a week (in case of continuous operation)
- after each service event (maintenance or repair work).

1.10 Protective Equipment



WARNING!

The operating company is responsible for identifying proper measures for handling the fluids and gases used in the filter unit.

Within this scope it must be determined:

- which protective equipment must be worn or be kept ready in case of need
- which measures must be taken to avoid dangers.

1.11 Safety during Operation



WARNING!

Prior to starting up the filter unit the operator must be sure that

- there is no danger for any personnel
- no material assets can be damaged



WARNING!

After completion of operation, do not open the filter unit before

- it is depressurized
- it is completely drained
- all feed and discharge pipes are closed.

Avoid any risks when working with the unit.

These operating instructions do not replace a correct commissioning and introductory operator training. We recommend a training carried out by a qualified Pall employee.

1.12 Safety during Maintenance

1.12.1 Maintenance Work

Prior to maintenance and repair work it might be necessary to remove the installed safety and protection devices. After having finished the work they must be reinstalled and reinspected.

Protective and safety devices are:

- Safety valve or rupture disc

Parts of the assembly which are situated at high clearances off the ground must be accessed by secure steps, platforms, ladders and in some cases scaffolding.

Never use parts of the filter unit to climb on.

All maintenance work shall be in line with the operating company's current safe practices and applicable health and safety rules.



DANGER!

The use of damaged lifting equipment or load lifting devices or the use of equipment not providing a sufficient supporting or load capacity can cause severe, even deadly injuries.

Therefore check the lifting equipment and load lifting devices for their

- sufficient load capacity
- authorized use
- perfect condition.

Fix the loads carefully!

Never step under suspended loads!

1.12.2 Accident Report

Accidents are to be reported as per the operating company's health and safety procedures and legislations, and Pall Corporation informed officially of such occurrences, sources of danger as well as "near accidents".

"Near accidents" can have many causes.

The sooner they are reported the sooner the faults can be rectified



Information

We draw the attention of the operating company to high risks of dangers when working with and around the filter unit.

1.13 Chemical Substances

When working with

- acids
- caustic solutions
- oils
- solvents and cleaning agents
- other chemical substances

observe the corresponding safety regulations on the packaging and in the material safety data sheets as well as in these operating instructions.

1.14 Fire

In case of fire, poisonous gas may be produced due to chemical reactions involving any synthetic materials or cleaning agents that may be contained in the filter unit.



DANGER!

The use of unsuitable fire-extinguishing media may cause further danger. Prior to commissioning the unit, adequate and suitable fire extinguishing media must be identified, depending on which types of flammable substances involved. If necessary, please contact your local firefighting authority for competent advice.

Should you try to extinguish a fire close to electrical installations or high-voltage lines, always keep a safe distance.

1.15 Remaining Hazards

There are still remaining hazards that cannot be secured through the applied safety and protection devices.

These might for example be:

- suspensions or cleaning liquids squirting out of pipes and their connecting pieces
- further sources of energy (i.e. electrostatic charges)
- hot equipment surfaces
- escaping steam, solvent vapor etc.

However, these hazards do not represent any defects in connection with the manufacture of the filter unit.

They rather represent sources of danger that might occur during operation by the user and when integrating the filter unit into an already existing installation.

The operating company must identify these dangers within a hazard analysis program and then take suitable measures to eliminate them.

2 General Information

2.1 Identification

The following identification plate can be found on the housing cover.

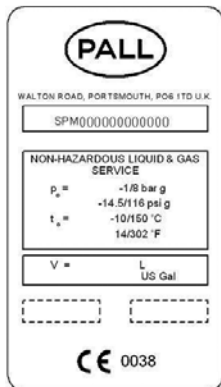

Fig 2-1: Nameplate on filter housing

2.2 Operating Data, Connections, Measurements and Weights

Feed Fluid-Inlet	1 x DN 40 DIN 11851 1 x 1.5 inch clamp coupling (ISO 2852)
Filtrate-Outlet	1 x DN 40 DIN 11851 1 x 1.5 inch clamp coupling (ISO 2852)
Vent	Feed Fluid 1 x DN 6 (8 mm/ 0.31 inch hose tail)
	Filtrate 1 x DN 6 (8 mm/ 0.31 inch hose tail) (optional)
Drain	Feed Fluid 1 x DN 15 (18 mm/ 0.71 inch hose tail)
	Filtrate 1 x DN 15 (18 mm/ 0.71 inch hose tail)
Design Pressure	max. 8 barg (116 psig)
Design Temperature	max. 150 °C (302 °F) The maximum operating temperature is limited by the material of the standard seals (130 °C/266 °F) and the temperature limits of the filter modules. Please consult Pall.
Volume (housing, empty)	27 to 88 l (7.1 to 23.2 US gal)
Weight (empty)	approx. 40-68 kg (87-149 lbs) (without accessories)
	approx. 56-84 kg (123-185 lbs) (with accessories)
Dimensions and Variants	Please request drawings CC70946D00 (WA version) and CC70957D00 (SA version).

2.3 Footprint and Operator's Position

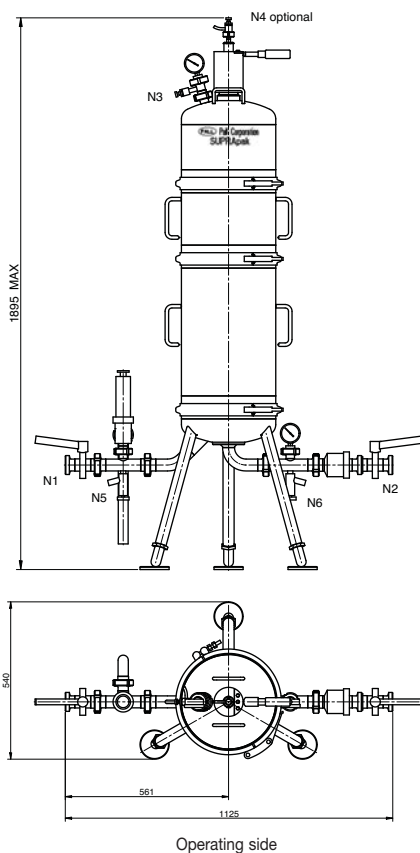

Fig 2-2: Footprint and operator's position — shown without optional filtrate side sight glass

3 Assembly and Function

3.1 About this Chapter

In this chapter you will find all functional units of the filter described:

- where they are
- how they are identified
- what their function is
- how they work together

3.2 General View

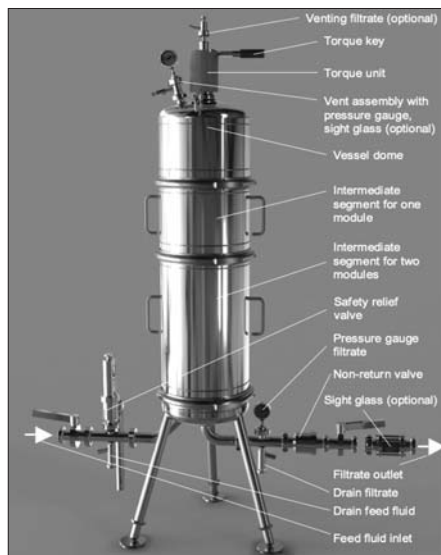

Fig. 3-1: Type SPMSA421TVNW40*, showing Standard and Optional Accessories

3.3 Operating Data – Housing

(⇒ Chapter 2.2 Operating Data, Connections, Measurements and Weights)

3.4 Safety Warnings – Pressure Vessel

The pressure unit is designed and constructed according to the pressure equipment directive 97/23/EC.



WARNING!

The operating company must assure that the inlet (feed) pipe of the filter is outfitted with a suitable safety device, if it is not provided as an accessory. The safety device consists of a safety valve or rupture disc, to protect the system against exceeding the acceptable pressure limit. (⇒ Chapter 2.2 Operating Data, Connections, Measurements and Weights)



An authorized expert should do the legally required pressure vessel checks and inspections. Depending on the pressure vessel category of the filter unit, a pressure vessel check must always be done:

- prior to the first commissioning
- after any modification
- after repairs of the pressure vessel
- in restricted periods (according to local requirements)



WARNING!

Note the operating limits listed on the housing identification tag. The maximum values indicated must never be exceeded under any circumstances!

3.5 Safety Valve



WARNING!

In case the excess pressure protection device is activated due to an overpressure situation, steps must be taken to avoid uncontrolled leaking of the product (in case of corrosive or toxic fluid escape, refer to the user's safety handling procedures).



WARNING!

The safety valve (if included in the accessories) is adjusted to the maximum allowable fluid pressure and prevents excess pressure by draining off the liquid.



WARNING!

Should the safety valve be activated due to an overpressure situation, a spraying of fluid (i.e. caustic solutions or acids) may occur. Position the safety valve in such a way that any escaping fluids do not cause a hazardous situation (i.e. directed to drain, or extending with a hose to drain!)

3.6 Vent units

Venting on the feed fluid side is done via valve HV03 (⇒ Fig. 5-1 Process and Instrumentation Diagram). The pressure gauge on this vent unit indicates upstream system pressure. An optional sight glass can be provided as an accessory for mounting on this vent valve.

Venting on the filtrate side (HV04) is optional. This option allows venting of the SUPRApak filter unit on the filtrate side when filling the unit.

3.7 Drain valves

Drain feed fluid inlet HV05:

At the inlet side below safety valve.

Drain filtrate HV06:

At the filtrate outlet side below the filtrate pressure gauge.

3.8 Isolation valves

Butterfly valves (manually operated) HV01, HV02.

3.9 Non-return valve

Located at filtrate outlet side after pressure gauge and drain valve, valve NRV01.

The non-return valve prevents a reflux of the filtrate into the vessel and, at the same time, prohibits backflushing or pressurizing from the outlet side.



ATTENTION!

The filter must neither be backflushed nor pressurized from the discharge side.

If this occurs: The SUPRApak modules would be destroyed!

Pressurization is only allowed in a forward flow (filtration) direction!

3.10 Functional description

The feed fluid enters the vessel via HV01. Due to the existing liquid supply pressure, the feed fluid flows through the SUPRApak filter modules into the central filtrate space and exits the vessel at HV02.

4 Installation

4.1 About this Chapter

In this chapter you will be informed about:

- the transport
- the installation/ assembling
- the connecting of the filter unit, as well as
- the mounting and dismounting of the SUPRApak modules



WARNING!

Improper installation of the filter unit may

- endanger personnel
- result in material damage.

Only qualified and experienced assemblers should execute the activities described in this chapter.

4.2 Delivery and Storage

When delivered, immediately check the filter unit for:

- completeness (according to the delivery documents)
- damage



Information

Immediately inform the forwarder in case of missing parts or transport damage.

Request the forwarder to confirm the damage in writing.

In case the filter unit is not installed immediately after delivery store it

- dry
- free from dirt and dust
- in a non-corrosive environment

In case of a longer storage period, use suitable long-term storage procedures.

Should you have any questions please use the "Product Observation" form. (⇒ Chapter 7.3 Product Observation).

4.3 Transport



Information

The filter unit is delivered in a shipping crate. The weight of the filter unit is indicated in the delivery documents.



WARNING!

The use of damaged lifting equipment or load lifting devices resulting in the use of equipment not providing a sufficient supporting or load capacity can cause most severe, even deadly injuries.

Fix single parts and larger structural components carefully and safeguard them in a way that they cannot constitute a danger.

Check whether the lifting equipment and the load lifting device

- provide a sufficient load capacity and are not damaged.
- are provided with a test certificate (and a CE-label).



WARNING!

Never step under suspended loads!

Safeguard the piping in a way that it cannot be damaged during transport.

4.3.1 Information about the transport of the SUPRApak Filter Unit

- The length of the rope used for slinging should be sufficient to allow a vertical hanging of the filter unit.
- Secure the ropes against slipping by means of safety devices.
- Only trained and qualified personnel should be employed for lifting, to avoid equipment and personal damage or injury.

4.4 Unpacking, Cleaning and Installation

4.4.1 Requirements for the Installation Location



CAUTION!

The filter unit's center of gravity is not located in the center. Care must be taken to avoid swinging during the handling of the equipment.

The SUPRApak Filter Unit must not be transported with installed SUPRApak modules.

Configure the working area around the filter unit according to the general applicable health and safety regulations.

The working area for operation, commissioning and maintenance must not be confined.

Surrounding conditions and environmental conditions

- Surrounding temperature: -10 °C to +80 °C (14 °F to 176 °F)

Operation is only permissible in non-corrosive surroundings.

4.4.2 Unpacking

- Remove the shipping packaging and all transportation safety devices.
- Remove all packing materials and adhesive tape residuals from the filter unit.

4.4.3 Installation

The filter unit will be delivered disassembled and must be installed.

The installation area must correspond to the applicable health and safety regulations.

The load-bearing capacity of the ground must be considered, taking into account the weight of the unit when filled.

The installation location should be flat and dry.

Put the filter unit on the plates of the cap-shaped feet.

Level the filter by means of the adjustable feet, then fix the feet in place with the counter nuts.



ATTENTION!

Exercise caution to ensure that the heavy accessory fittings are supported properly to avoid tipping of the filter housing.

4.4.4 Cleaning of New Units

New filter units must be carefully cleaned before the first commissioning. If necessary disassemble the filter unit for cleaning. (⇒ Chapter 4.6 Assembly/Disassembly Instructions)

Clean individual parts with a soft brush or paint brush in a bowl with hot cleaning solution (cleaning solution: hot water with neutral detergent). The filter inlet and outlet pipes, fluid connecting passages as well as the sealing grooves must be cleaned with special care.

After cleaning, rinse with clear water, especially the product-wetted parts. In case of critical applications, i.e. in pharmaceutical applications, rinse with demineralized water.

- 4.5 Safety Warnings – Pressure Vessel
 (=) Chapters 3.4 Safety Warnings, and 3.5 Safety Valve)



ATTENTION!
 Should the filter unit be hard piped to surrounding pipework, axial and radial forces acting on the filter unit connections should be avoided.



ATTENTION!
 If fluid is leaking from the filter housing or the fittings, this is an indication that the housing lid or the fittings are not correctly mounted or the seals are defective. Immediately stop filtration and look for the cause of the leakage.

A suitable hose or a pipe must be connected by the operating company at the vent and drain connections to direct fluid into a suitable vessel.

- 4.6 Assembly/ disassembly instructions filter unit and accessories
 (=) Fig. 3-1, General View)

- 4.6.1 Opening and lifting the dome of the filter housing



WARNING!
 Before opening the filter housing, ensure that the housing and/or the system is not under pressure!

Opening: Turn torque key counterclockwise to open the filter housing. Open the clamp ring (V-band). Then lift the housing dome using the handles which are fitted for this purpose. In case of larger/ higher housings it is advisable to have 2 persons lift the dome.

If the filter is equipped with modules, it has to be observed that the housing dome is carefully lifted over the SUPRApak modules, and placed so that the sealing surface will not be damaged.

Mounting and dismounting of the SUPRApak modules by means of the appropriate lifting device. (=) Chapter 4.8 Lifting Device)

- 4.6.2 Equipping the filter with SUPRApak modules
 Place the O-ring in the housing O-ring groove. By slight pressing the O-ring will fit into the groove.



O-ring, housing sealing

Filtrate flange

Fig. 4-1

The installation of SUPRApak modules is done manually.

Place the first SUPRApak module directly on to the filtrate flange. Note: there is no gasket needed at the filtrate flange. When inserting, please observe that the plastic drainage core of the SUPRApak module catches centrally in the filtrate flange.

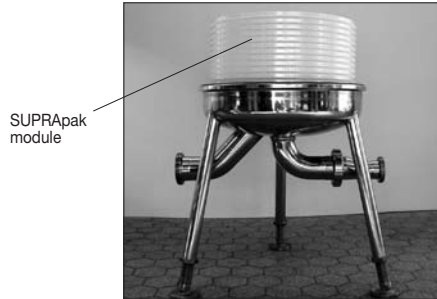

SUPRApak module

Fig. 4-2

Depending on the design type an intermediate piece or the housing dome will then be positioned. (=) Chapter 4.6.3 Positioning of the Dome)

Fit O-ring into groove by pressing slightly.



Fig. 4-3

Intermediate piece:

Depending upon the design type:

Z1: Single-height intermediate piece
 Z2: Double-height intermediate piece

The intermediate pieces can be combined with each other thus offering the possibility of extension by one or two intermediate pieces.

For sealing purposes, an intermediate plastic ring (supplied in each SUPRApak module box) is placed between each SUPRApak module. Please hereby observe that the ring is exactly centered in the drainage core.

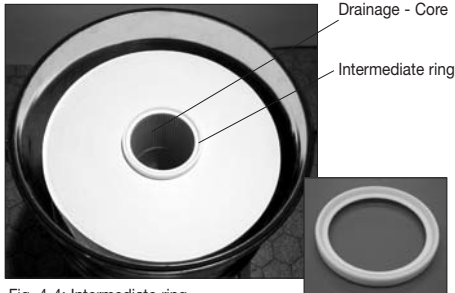

Fig. 4-4: Intermediate ring centered in the SUPRApak module

Fig. 4-5: Intermediate ring

When inserting several modules:

Insert all further SUPRApak modules as described.

Insert SUPRApak module and intermediate ring alternately (Fig. 4-4 and 4-5)

The intermediate ring serves as a centering aid for the next SUPRApak module.

When placing the subsequent SUPRApak modules please observe again that they are exactly centered and properly positioned.

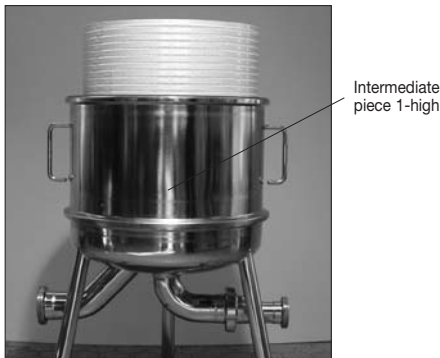

Fig. 4-6: SUPRApak housing with 2 SUPRApak Modules and intermediate piece 1-high

Do not place an intermediate ring onto the topmost SUPRApak module in the stack. The sealing function is ensured by the tensioning device which is fitted at the top of the housing dome.

4.6.3 Positioning of the dome and closing of the filter housing

Turn torque key counterclockwise until only one complete turn of the thread is left. Then slowly lift the housing dome over the SUPRApak modules onto the housing bottom or the intermediate piece. Pay attention to exact alignment.

- Close the clamp ring (V-band).
- Pre-tighten the SUPRApak modules. For this, turn the torque key clockwise until the lever buckles.



WARNING!

The torque unit was calibrated in dry condition and therefore the SUPRApak modules must be dry when the torque is applied.

Do not move the torque key jerkily and do not draw it obliquely downward or upward.



Fig. 4-7: Closing

Closing:
Turn torque key clockwise (in direction of the arrow) until the lever buckles.



Information

To ensure appropriate force is exerted by the tightening torque, all parts shall be clean and free from any contamination. Special attention should be paid to the sealing surfaces.



CAUTION!

The operating company must ensure that all gaskets are monitored at regular intervals. They must be checked for damage and leakage.

In case of defective gaskets the filter must not be operated any further and the gaskets must be replaced immediately.



ATTENTION!

All O-rings and other gaskets are made of EPDM material as a standard.

Other seal materials are possible, for further information please contact Pall.

- 4.6.4 SUPRApak Filter Unit with standard accessories:
 (= > Fig. 3.1 General View)
 Filter inlet side: Connect the butterfly valve and safety valve.
 Filtrate Side: Connect the non-return valve and butterfly valve.
 Ensure that there are sealing rings (gaskets) between all connection pieces.



CAUTION!

If the filter unit is to be integrated into a pipeline, it must be ensured that no axial forces interfere with the connecting pieces.

4.7 Connecting

The user must connect suitable hoses to all vent and drain valves. (For connection sizes => Chapter 2.2 Operating Data, Connections, Measurements and Weights)

- 4.7.1 Compressed air, inert gas (optional)
 In many applications operators choose to displace the product from the inlet pipe, filter housing, and filter module by means of compressed air or inert gas.
 When using pressure from a pressure vessel, the inlet pipe can be used for liquid displacement.
 When using a pump for this purpose, a pressure pipe or pressure hose should be installed on the inlet side for pressure-assisted emptying.
 Pressure regulation is possible by means of a precision-regulating pressure gauge, with gradations from 0.1 to 3 bar maximum.

- 4.7.2 Rinsing liquid (optional)
 In many cases the product displacement is supposed to be carried out with the aid of liquids, e.g. with water, solvents or special rinsing solutions. Thus, solid matter can additionally be washed out. If required, the modules can also be pre-rinsed.
 The operating company should check whether the product feed pipe can also be used as the rinsing pipe, or whether an additional rinsing pipe must be installed.

- 4.7.3 Hot Water Sanitization
 Depending on the type of SUPRApak modules in use, sanitization with hot water in a forward flow direction of filtration with a maximum temperature of 85 °C (185 °F) is recommended for an individual period of 20 minutes. For maximum cumulative exposure, please refer to SUPRApak module operating instructions (FBSISPAK), or please consult Pall. No back pressure is allowed. Water quality: If possible, use demineralised water, free from contamination.

4.8 Lifting device for SUPRApak modules (optional)

The lifting device only works in connection with a corresponding lifting tool (e.g. a crane).

Removing the SUPRApak modules from the housing is only possible as a complete stack, i.e. the modules cannot be removed individually with this device. Mounting of the complete stack outside the filter housing:



Fig. 4-8

Place the plastic ring supplied with the lifting device (as a spacer, with min. height of 100 mm) on a flat surface, to take up the first SUPRApak module.

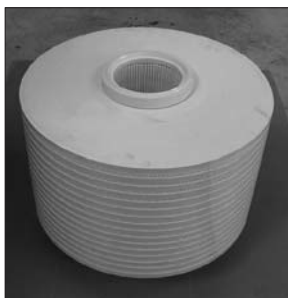

Fig. 4-9

Set the first SUPRApak module on the plastic spacer ring, then insert the intermediate ring. For further assembly, insert SUPRApak module and intermediate ring alternately as described above.

Important: Only use intermediate rings between the SUPRApak modules. No intermediate rings are needed at the upper and lower stack ends.

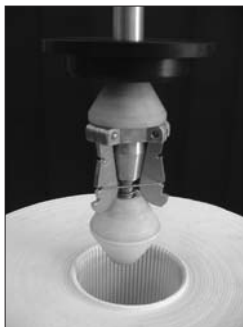

Fig. 4-10

Bring the lifting device in an exactly centered position above the SUPRApak module.



The plastic disc has to be centered into the drainage core of the SUPRApak module

Fig. 4-11



Move the lifting device downward until the plastic cone rests on the bottom



Keep the rod pressed down at the ring simultaneously moving the crane slowly upward until the stack lifts off from the bottom



The screw head is now in the upper position



Turn the rod until the screw head fits at the left end of the slot. The lifting device is now locked

Fig. 4-12 to 4-15



Fig. 4-16 and 4-17: Put the spring connector into the hole at the disc. The locking mechanism of the lifting device is now safe.



Fig. 4-18 and Fig. 4-19: Continue to move the crane slowly in an upward direction and check whether the hooks are completely latched and fit close at the core.

Installation of the complete stack into the filter housing



Fig. 4-20
The complete stack is moved centrally above the housing bottom.

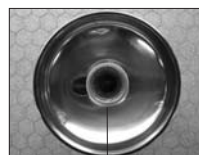

Fig. 4-21
Introduce the plastic cone at the bottom part of the lifting device centrally into the filtrate flange and move the crane slowly downward until the lowest module is evenly centered onto the sealing grooves.

Removal of lifting device from the module stack:

For unlocking pull the spring connector, then turn the rod until the screw head closely fits at the right side of the vertical slot.

Lower the crane until the rope is relieved. Move the crane slowly upward until the entire lifting device has come out of the stack.

The next step is to close the housing.

(⇒ Chapter 4.6.3 Positioning of the dome and closing of the filter housing)

5. Operation and Process Description

5.1 About this Chapter

In this chapter you will be informed about the safe operation of the filter unit.

5.2 Prior to Commissioning

Start the filter unit only if all of the following conditions are fulfilled:

- technically perfect condition of the unit
- correct intended use
- related work activities heed safety warnings and exercise awareness of potential hazards
- operating instructions are followed
- all safety and protection devices are available and ready for use
- access by unauthorized persons is forbidden
- commissioning is done only by skilled personnel.



WARNING!
Immediately eliminate failures that could compromise safety.

5.3 During Operation

5.3.1 Safety



WARNING!
Avoid any work activities which could compromise safety!
Immediately eliminate failures or have them eliminated!
Immediately inform the responsible personnel about occurring changes!
Immediately stop the filter unit in case of any functional trouble, and protect it against unauthorized use!

5.4 Initial Commissioning / Test Run

Designation of the operating elements:

Item/Name	Designation	Function
F01	SUPRApak filter unit	Filter vessel
HV01	Butterfly valve	Feed fluid inlet
HV02	Butterfly valve	Filtrate outlet
HV03	Seat valve	Vent (feed fluid)
HV04	Seat valve	Vent (filtrate - optional)
HV05	Seat valve	Drain (feed fluid inlet)
HV06	Seat valve	Drain (filtrate outlet)
SV01	Safety valve	Overpressure protection
PI01	Pressure gauge	Operating pressure, filter inlet
PI02	Pressure gauge	Operating pressure, filter outlet
NRV01	Non-return valve	Filtrate downstream
SG01	Sight glass	Feed fluid vent assembly (optional)
SG02	Sight glass	Filtrate outlet (optional)

5.4.1 Test Run

During the test run observe the tightness and the pressure of the unit and surrounding installation.

5.4.2 Controls prior to the Test Run

- Check whether
- all protection and safety devices are firmly fixed and functioning
 - all potential hazard sources are secured

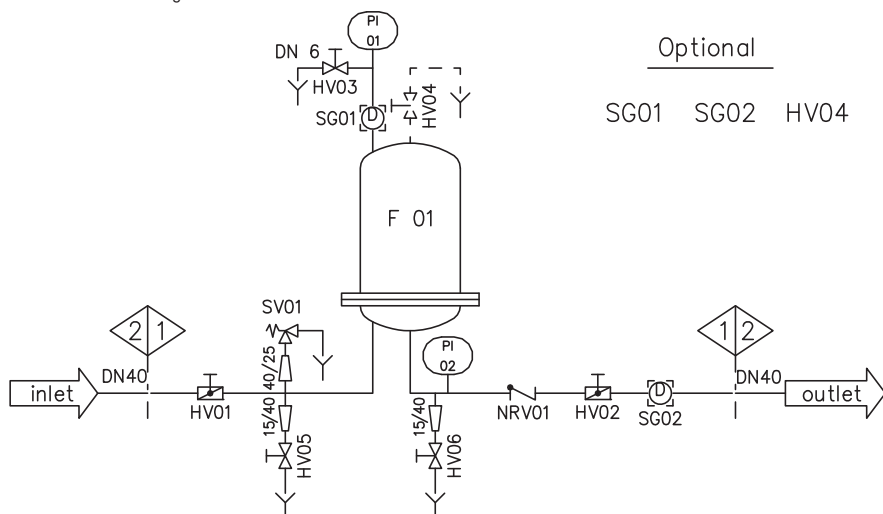

Fig. 5.1 Process and Instrumentation Diagram



WARNING!

Several process steps can cause heating of equipment parts and surfaces. If touched, this can cause burns. Place warning signs at the filter unit and block off the area surrounding the filter unit as long as it is hot.

- all hoses and connections are firmly tightened
- all valves are closed
- the feed and discharge pipework for the feed fluid and the filtrate is connected correctly

5.5 Filtration

In general, a filtration with pre-rinsing is recommended. Such a procedure is described in Chapter 5.5.1. If it is intended to carry out filtration without pre-rinsing, please proceed directly as described in Chapter 5.5.2 or 5.5.3.

5.5.1 Pre-rinsing

5.5.1.1 When should pre-rinsing be carried out?

Pre-rinsing of filters is carried out if specific filtrate requirements must be fulfilled.

Due to the fact that feed fluid might flow into the filtrate pipe when changing filters, this should also be a reason to pre-rinse the filter and the outlet pipe.

5.5.1.2 Which medium is recommended for pre-rinsing?

With regard to filtrate requirements the user will choose:

Pre-rinsing with water:

- It is recommended to pre-rinse with 140 litres of water per SUPRApak SW/M-module. (⇒ SUPRApak module operating instructions: FBSISPAK)

or

- Pre-rinsing with a specific solution: e.g.: cold or hot water, distilled water, solvents suitable for modules, citric acid, and others.

or

- Pre-rinsing with the product to be filtered (lowest expenditure, because a discharge or a displacement of the rinsing solution is not necessary)
- Depending on the user's requirements, the rinsing solution may be discarded or further used.

The rinsing quantities must be determined according to the respective requirements on the product to be filtered.

5.5.1.3 Process description for pre-rinsing

During filling the filter unit needs to be vented.

- Venting valves HV03 and HV04 are opened
- Valves HV01 and HV02 at filter inlet and outlet side are opened
- Butterfly valve HV02 (outlet):
If required throttle slightly until venting is effected, then open completely

As soon as the filter is filled, the drain valves HV05 and HV06 must be opened momentarily in order to vent and rinse them as well.

A precondition is the corresponding installation of the required tanks (rinsing agent, pre-fill recipient, collection tank) and piping on site. Drainage of the rinsing solution or the filtrate (⇒ Chapter 5.5.5 Emptying).

5.5.2 Hot Water Sanitization (if necessary)

5.5.2.1 When should sanitization be done?

Hot water sanitization of the filter unit and accessories must be done in case of specific requirements of the filtrate.

For details regarding hot water sanitization, please refer to SUPRApak module operating instructions (FBSISPAK), or consult Pall.

5.5.2.2 What medium should be used for sanitization?

Hot water is to be used for sanitization.

5.5.2.3 Process description for hot water sanitization

- Valves HV01 and HV02 at filter inlet and outlet side are opened.
- Valves HV03 and HV04 must be opened momentarily for venting.

After having achieved the required hot water sanitization temperature (max. 85° C):

- Open venting valves HV03 and HV04 as well as discharge valves HV05 and HV06 for approx. 5 min. to sanitize these as well.

The duration of the hot water sanitization depends on the product; however, this should be between 20 and 25 min.

If the housing assembly is sanitized prior to installation, it is recommended that the connecting pipework must be sanitized prior to connection.

Alternatively the housing assembly can be connected in the system, then the whole system is sanitized.

5.5.3 Filling with Product and Filtering

5.5.3.1 Filling

- Valves HV01 and HV02 at filter inlet and outlet side are opened
- Venting valves HV03 and HV04 are opened
- Drain valves HV05 and HV06 are closed
- If necessary throttle outlet valve HV02 until fluid comes out of the vent valve.

5.5.3.2 Pressurization

- Fill equipment with fluid, until product emerges from vent valve HV03 and HV04.
- Ensure total venting indicated by absence of gas bubbles in transparent hose or optionally supplied feed fluid vent assembly sight glass. Close vents HV05 and HV06.
- Gradually increase the internal pressure to the system operating pressure, but NOT exceeding the maximum allowable pressure.
- Gradually open outlet valve HV02 until fully opened.

Note: The module should be replaced when the recommended maximum differential pressure is reached (⇒ SUPRApak module operating instructions: FBSISPAK).

5.5.4 Rinsing after Filtration (if necessary)

5.5.4.1 When should rinsing be done?

Depending on process and product a rinsing might be necessary to eliminate the product out of the filter, i.e. when

- Changing the product
- Rinsing the modules
- Preparing a filtration change
- Preparing the disposal

The rinsing can be done with hot or cold fluids and with different media.



WARNING!

In case the rinsing is done with hot media, absolutely note:

- ⇒ Chapter 5.6 Use of SUPRApak modules at higher temperature or increased viscosity applications.
- ⇒ Operating instructions SUPRApak modules (FBSISPAK)

- 5.5.4.2 Process description for Rinsing
Normally the rinsing of the SUPRApak modules directly follows the filtration:
- Valves HV01 and HV02 at filter inlet and outlet side are opened
 - Open valves HV03 and HV04 momentarily for venting
- When rinsing with hot media the temperature will be increased slowly from 20°C, 40°C up to 60°C. Thereby filtration residuals dissolve little by little in the module whereby the pressure difference decreases. By means of this operation mode the use of a stainless steel supporting pipe, as mentioned in Chapter 5.6, is not essential during rinsing.

However, product-specific pilot tests should be done.

As soon as the rinsing temperature is achieved it can be run in circuit.

- 5.5.5 Emptying
5.5.5.1 Emptying without pressure
- Close valve HV01
- Completely empty inlet side first by
- opening valve HV03 and HV05
- Then open outlet side by
- opening valve HV02 and HV04
- or
- opening valves HV04 and HV06 (recirculation of the discharged volume towards the feed fluid side or drain)



ATTENTION!

When proceeding in reverse order this might result in a vacuum at the outlet side.

- 5.5.5.2 Emptying after pre-rinsing
In case of processes with pre-rinsing: after having drained the liquid carry out filtration according to 5.5.3. The residual rinsing solution is thereby displaced from the SUPRApak module. Should this blend disturb the filtrate, reject the pre-run.

5.5.5.3 Displacement with pressurized gas



ATTENTION!

When using pressurized gas, the maximum allowable vessel pressure must be observed (see type plate).

Displace liquid in a forward flow direction. Use air, sterile air or inert gas as pressure gas. Feed via separate pressure pipe or via vent valve HV03.

Start with the lowest possible pressure, receive the displaced filtrate either at the drain valve HV06 or at the filtrate pipe HV02.

After having drained the filtrate side close valves HV02 and HV06. Carefully open drain valve HV05 and discharge feed fluid and / or rinsing solution.

After complete displacement of:

- Rinsing solution: Start with filtration (⇒ Chapter 5.5.3)
- Filtrate: Dismounting of SUPRApak modules (⇒ Chapter 4.6 and 4.8)
Cleaning (⇒ Chapter 5.7)

Rinse filtrate connecting piece in the base plate and the filtrate pipe.

- 5.6 Use of SUPRApak modules at higher temperatures or increased viscosity applications (sugar syrup, gelatine etc.)
- 5.6.1 Use at filtration temperature > 40 °C
When using the SUPRApak modules at operating temperatures above 40 °C, a stainless steel core has to be fitted into the center core of the module. (⇒ Fig. 5.2 and 5.3)



Fig.: 5.2 Stainless steel core



Fig.: 5.3 Mounted inside a SUPRApak module

If a stack of several modules is used, the stainless steel core has to be fitted in each module.



ATTENTION!

The stainless steel core is available in two different lengths!

- Same length as the drainage core of the SUPRApak module and
 - Approx. 20mm shorter than the drainage core
- The supporting pipe, being 20 mm shorter, always has to be installed into the topmost SUPRApak module, i.e. if you only work with one module you need only the short supporting pipe.

- 5.6.2 Rinsing before filtration at $T > 40\text{ °C}$ (i.e. 70 °C for sugar syrup)

The SUPRApak module should be rinsed directly before use with rinsing fluid of the same elevated temperature. Rinse and heat up the SUPRApak module to filtration temperature. Otherwise when flowing i.e. hot sugar syrup through the cold SUPRApak module, the syrup may get cold resulting in higher viscosity or even crystallisation within the module, and the unit may become blocked or even be damaged.

- 5.6.3 Interrupting the filtration at $T > 40\text{ °C}$

When interrupting (or stopping) a filtration that is run at elevated temperature with a feed fluid that increases its viscosity when cooling down, the SUPRApak module should be rinsed out with hot water before stopping the process. Otherwise, the feed fluid may thicken or even crystallize within the cooled module, and the module may be irreversibly blocked or damaged and can not be used any longer.

Alternatively, if only a short break is necessary, circulation of the hot medium in a closed loop for this short time may be possible.

5.7 Cleaning the Housing



WARNING!

Before opening the filter housing confirm that it is absolutely depressurized.

Hot equipment surfaces can cause burns. Let the filter unit cool down.

Cleaning the filter housing must be done as necessary in the absence of product and filter modules, by means of detergents suitable for stainless steel. An additional cleaning with a soft brush is possible.

(⇒ Chapter 4.4 Unpacking, Cleaning, and Installation)

We recommend rinsing the filter housing with sufficient water after the cleaning to completely remove any remaining detergent residues.



ATTENTION!

Exercise caution when cleaning or dismantling the diaphragm pressure gauges.

5.8 Disposal



ATTENTION!

When disposing of used filter modules:

Please follow locally applicable disposal directions.

6 Service

6.1 About this Chapter

This chapter deals with servicing the filter unit. Activities are organized according to:

- Inspection
- Maintenance
- Repair

The diagram below gives a suggested overview:

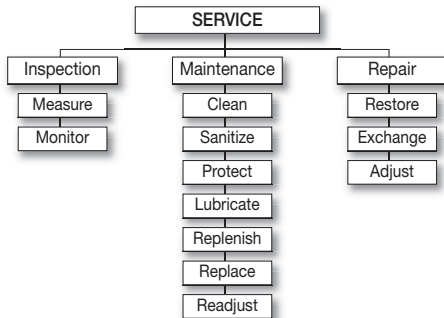

Fig 6-1: Organisation of Service Activities



ATTENTION!

Regularly, properly executed service is an essential condition for:

- operational safety
- trouble-free operation
- long service life of the filter unit.



ATTENTION!

Even devices and units of other manufacturers being used around the unit must also be in perfect condition.

Please note the instructions of the respective manufacturers!

6.2 Safety



WARNING!

Improperly executed service and maintenance may lead to:

- serious personnel injuries
 - damage of the unit
- Only qualified skilled personnel are allowed to service the unit.



WARNING!

All safety valves if provided by Pall Corporation are adjusted to the correct pressure and sealed.

Do not

- take them out of operation.
- alter or adjust them unless Pall Corporation has been consulted.

6.2.1 Preparation



WARNING!

Do all maintenance and repair work only when the filter unit is

- not in operation and
- depressurized.

Safeguard unauthorized product feed by separating the feed and discharge pipes from the filter unit.

6.2.2 Returning to Operation



WARNING!

Prior to starting the filter unit ensure there is

- no danger for personnel
- no danger for material assets.

6.3 Inspection and Maintenance



WARNING!

If a defect has been identified which could cause

- danger for personnel
- damage to equipment, you must
- immediately stop the unit,
- inform a maintenance technician.

If the process step can be continued despite the identified defect without endangering personnel or equipment:

- shut down the unit after process completion
- inform a maintenance technician.

Interval	Where	Looking for?	How
Daily	Complete filter unit	<ul style="list-style-type: none"> • externally visible damages and defects • leak tightness 	Visual check for <ul style="list-style-type: none"> • damage • leakage (drain of liquids)
		<ul style="list-style-type: none"> • Connections • Tightness 	<ul style="list-style-type: none"> • Check for tightness and re-tighten. • In case of leaky connections, dismount gaskets, check them and replace if necessary
When changing filter modules	Gaskets	<ul style="list-style-type: none"> • Externally visible damages, cracks or abrasion 	<ul style="list-style-type: none"> • Visual check for damage ⇒ replace!
	Vessel gasket	<ul style="list-style-type: none"> • Check for acceptable fit of gaskets in O-ring groove 	<ul style="list-style-type: none"> • Visual check the total circumference
Weekly	Complete filter unit	<ul style="list-style-type: none"> • Hose lines 	Check for <ul style="list-style-type: none"> • chafe marks • tightness
Monthly	Vessel gasket	<ul style="list-style-type: none"> • Dirt, abrasion, damage • Check correct fit 	<ul style="list-style-type: none"> • After opening the vessel, clean O-ring, check for cracks and abrasion and exchange it if necessary.
Every 3 months	Clamp ring (V-band)	<ul style="list-style-type: none"> • Fit of gripper clamp 	<ul style="list-style-type: none"> • Adjust gripper clamp in unstressed condition
Annually	Gaskets	<ul style="list-style-type: none"> • Dirt • Abrasion • Damage 	<ul style="list-style-type: none"> • Renew the gaskets of the whole filter unit
	Torque unit rod seal	<ul style="list-style-type: none"> • Exchange the lip seal at the upper vessel bottom 	See following instruction ⇒ Chapter 6.3.1

6.3.1 Demounting/Mounting of Clamping Device and Exchange of Torque Unit Rod Seal

Open the vessel. (⇒ Chapter 4.6.1 Opening the filter housing and lifting the dome)



WARNING!

The torque unit is under spring preload (approx. 600 N). In case of an improper demounting, a sudden release of the spring might lead to injuries!

Two persons are necessary for the demounting/mounting of the white plastic cap. As a mounting tool for example a used SUPRApak module can be of help.

As seen in Fig. 6-1 it is put onto the bottom and the top of the vessel is set on top of it. While doing so please ensure that the plunger is centralized in the module.



Fig. 6-1



ATTENTION!

Adjust the plastic cap by at least one complete turn.

- One person has to push the vessel top downwards until the safety ring lifts from the white plastic cap. See Fig. 6-1.
- Now the second person can demount the safety ring. (Use a special pincer for this.)

Then carefully loosen the vessel top (the spring releases) and lift evenly (without tilting) until the shaft of the plunger is totally free. Then completely screw off the white plastic cap.

Demounting/ Mounting of Torque Unit Rod Seal

The Torque Unit Rod Seal is situated in a groove underneath the flange and can be demounted/ mounted from the interior of the vessel.



ATTENTION!

When installing the Torque Unit Rod Seal please note that

- the seal is not damaged
- the seal completely fits into the groove.

Mounting of the Torque Unit

The mounting is to be done according to Fig. 6.2 to 6.5.



Fig 6-2:

- Centralize plunger onto the SUPRApak module
- Lubricate shaft and torque unit rod seal



Fig 6-3:

- Lower the vessel top evenly, without tilting even as the torque unit rod seal is pulled onto the shaft of the plunger.



Fig. 6-4:

- Attach spring



Fig. 6-5:

- Screw white plastic cap for at least 1 complete turn

- Again one person has to push with about 60 kg the vessel top downwards until the groove for the safety ring is to be seen above the white plastic cap (⇒ Fig. 6-1)
- Now the second person can mount the safety ring. (Use a special pincer for this.)
- As soon as the safety ring is engaged into the groove, carefully release the vessel top; now the spring is pre-stressed.
- At the end mount torque wrench (if it is not yet on the torque unit).

6.4 Repair

Recommendation:

For all repairs please request a service technician from Pall Corporation (⇒ Chapter 1.1 About this Chapter) Should qualified personnel of the operating company handle their own repairs these operating instructions must be observed in all aspects.

Pall Corporation assumes no liability and does not warrant against any damages and operating troubles which result from a non-observance of these operating instructions.



Danger!

There is risk of injury due to

- unexpected movement of parts i.e. butterfly valves
- hot surfaces
- unit parts and hose lines being under high pressure
- leakage or bursting of hoses

Prior to repair, separate the unit from all energy sources.

Ensure that all fittings are depressurized.



WARNING!

There is risk of injury or dangerous situations. Protection and safety devices removed prior to repair, must be reinstalled before restarting the filter unit.

For repairs, please use

- only functioning and suitable tools
- only original spare parts or serial parts explicitly released by Pall Corporation
- the points detailed in these operating instructions

7.3 Spare Parts

For a comprehensive listing of recommended spare parts, please consult Pall, and refer to equipment drawings and data sheets.

The sealing materials most commonly needed are listed here.

Description	Material No.
O Ring, 320mm x 8mm, EPDM 70 Shore	ACS1007EM
Torque Unit Rod Seal 50mm x 60mm x 8.1mm EPDM85	20031632-S

8. Explosion Protection (ATEX) (optional)

8.1 General

The filter housing facility must be included in the manufacturer's explosion protection document.

For the issuing of the Declaration of Conformity further effective Directives in addition to the Directive 94/9/EC (ATEX95) must be taken into consideration if applicable.

Through inclusion of the equipment into a facility further operating instructions may be required.

The limit of the supply of the assessment can be seen in drawings CC70946D00 (WA version housing) and CC70957D00 (SA version housing).

Diagrams, descriptions, maintenance and operating instructions (amongst others, Accessories) will be supplied with (⇒ Technical Documentation)

8.2 Marking



8.3 Process Description / Indication for a safe Operation

Filter housing facilities are pressure vessels in which filter elements are arranged. The filter element material is electrostatic chargeable.

The ignition by electrostatic or mechanical sparks is avoided by filtering of inert or non-ignitable gases.



WARNING!

Electrostatic discharges can not be excluded, especially when opening the filter housing or when taking out the filter modules. Therefore specific measures are determined for the individual operating steps!

8.3.1 Filling

Fluid friction at the filter tissue may result in electrostatic discharges. Therefore the filter must be filled with a sufficient volume of inert gas before filling in the product to be filtered in order to prevent that no explosive atmosphere can be formed inside.

If needed, the housing will be flushed repeatedly in such a way as to remove any residual air.

8.3.2 Filtering

Filtering is carried out under non-atmospheric pressures (e.g. 6 bar) and will only work if the filter elements are completely submerged in fluid.

During filtering under pressure, Directive 94/9/EC (ATEX) formally does not apply, as this only applies in the case of atmospheric conditions.

In this case an analysis according to the Ordinance on Hazardous Substances must be carried out.

During filtration the equipment may become electrostatically charged.

By removing the connection you have to act vice versa.

As electrostatic discharges cannot be excluded when removing the filter modules, an explosive atmosphere must not exist.



WARNING!

If there is a risk of gas production via the soiled filter modules the development of an explosive atmosphere has to be prevented through the above mentioned measures.



WARNING!

The operator has to ensure by suitable measures that no explosive mixtures will be formed in the interior!

8.3.3 Discharging the Filtrate (emptying under pressure)

Emptying of the filter must be carried out with inert gas. Depending on whether the explosive mixture is heavier or lighter than air, the inert gas must be introduced under pressure either at the top or bottom of the vessel. After discharge inert gas with a slight overpressure must be in the vessel.

8.3.4 Cleaning

Depending on the product cleaning is carried out by rinsing or by exchanging the SUPRApak modules. Before opening the vessel the filter medium must be flushed sufficiently so that after opening formation of an explosive atmosphere is prevented.

During cleaning the filter unit has to be kept under slight inert gas overpressure which also partially escapes via the cleaning media outlet. No explosive atmosphere will be formed in the vessel due to the lack of oxygen. In case inert gas escapes within the area of the cleaning media outlet, it must be ensured that this will not lead to dangerous conditions for the operators.

It is advisable to use electrostatic conductive cleaning media.

8.3.5 Mounting and Dismounting or Exchange of the SUPRApak modules

It is assumed that the filter unit is mounted, dismantled or exchanged in a new or cleaned condition, so that no explosive atmosphere can be formed. Otherwise the explosive atmosphere must be prevented by additional venting or suction.

Exchanging of SUPRApak modules with lifting device

In case the intended lifting device is used for filter module removal, an electrical conductive connection (i.e. grounding cable with pincer) between the lifting device and the grounding point of the filter stack has to be guaranteed prior to touching the lifting device with the filter module(s). Doing so it must be noted that **first of all** the grounding cable at the lifting device has to be fixed and that this only takes place at the intended grounding point of the filter module(s) outside of the eventually occurring EX-atmosphere.

8.3.6 Putting into Operation after Standstill

Before start-up the inertization of the filter unit must be ensured, especially if the putting out of operation was carried out without prior cleaning. It is assumed that the filter unit will be mounted and dismantled in a new or cleaned condition, so that an explosive atmosphere can not be caused. Otherwise, an explosive atmosphere has to be prevented by additional venting or suction and be monitored by transportable gas detectors.

8.4 Information for Safe Intended Use

The SUPRApak Filter Unit consists of a pressure vessel and serves as precoat filter for filtration of solid matters and particles from fluids.

The maximum surface temperature (to be on par with temperature of filter media) is limited by the highest possible temperature of the pressure vessel. (⇒ Chapter 2.2, Operating Data)

Dangerous liquids acc. to PED (97/23/EC) Art. 9 Group 1 and gases are filtered.

Letter "X":

The filter elements are electrostatically chargeable. Charge differences within the filter medium may result from filtration. Therefore electric discharges can not be excluded and the conditions of the information for safe operation (⇒ Chapter 8.3) or equivalent must be observed.

As the maximum surface temperature of the vessel is determined by the temperature of the fluid, the operator fixes the temperature classification. For determination of the temperature class or max. surface temperature by the operator the safety distances of EN 13463-1 resp. EN 1127-1 must be observed:

Maximum fluid temperature (°C)	Temperature class category 2G
440	T1
290	T2
195	T3
130	T4
95	T5
80	T6

Alternatively the actual surface temperature can be indicated in category 2G and must be indicated in category 2D directly.

- 8.5 Information for Safe Mounting / Dismounting
Before mounting, dismantling and opening of the vessel, the system must be pressureless, emptied, and the inlets and outlets must be shut off.
It must be guaranteed by suitable measures that no explosive atmosphere develops when opening the vessel.
- 8.6 Information for Safe Maintenance
When opening the filter vessel, the operator must definitely avoid by suitable measures (e.g. venting or suction) that there is no simultaneously external explosive atmosphere and no releasing fumes from the inside.
The inlets and outlets must be shut off safely so that no filter fluid flows in or out.
To prevent that the filter will be a source of release during operation, the technical tightness must be assured constantly by maintenance and supervision.
The filter element consists of electrostatic chargeable material. Electrostatic discharges cannot be excluded, especially whilst vessel is opened and during handling of the filter modules.
- 8.7 Information for Safe Installation
During installation and operation the operating instructions and design inspection certificates of the single components must be considered.
During installation of electric components EN 60079-14 must be observed.
The filter may only be connected by pipe and hose systems with derivation ability for electrostatic charges, which were integrated in the equipotential bonding.
The vessel has to be connected to the equipotential bonding.
Additional components must be listed in the required categories according to 94/9/EC.
The vessel does not contain any energy sources.
The surface temperature is determined by the filter fluid. Filtration is effected at pressures above 1 bar so that no dust will enter the vessel. The surface temperature is determined by the fluid and must not exceed 2/3 of the ignition temperature of the dust.
Dust deposits must be removed regularly, dust coats may not exceed 5 mm.
- 8.8 Information for Dangerous Areas
The surface of the filter can heat up. By suitable means it must be assured that the filter surfaces will not be touched.
The operator has to prevent securely any reactions between the external explosive atmosphere and the internal explosive mixtures.
- 8.9 Information for Safe Operative Range
The filter may be used according to its device category only in gas explosion protection area 2 or in dust explosion protection area 21.
These are areas in which it can be expected that an explosive atmosphere of gases, steams, fogs or dusts will be formed occasionally.
- 8.10 Information about Safe Operating Data, Limiting Values, Surface Temperature
The values for the admitted external temperature, the maximum media temperature and the admitted internal pressure are to be found in (⇒ Chapter 2.2, Operating Data, Connections, Measurements and Weights).
- 8.11 Information about Special Conditions for Use
According to the agreement with the manufacturer, sealing materials which are resistant to the filter fluids must be used.
After closing the vessel and prior to filtration the sealed closure has to be secured.



Pall Corporation

Pall Food and Beverage

New York – USA
+1 516 484 3600 telephone
+1 866 905 7255 toll free

foodandbeverage@pall.com

Visit us on the Web at www.pall.com

Pall Corporation has offices and plants throughout the world. For Pall representatives in your area, please go to www.pall.com/contact

Please contact Pall Corporation to verify that the product conforms to your national legislation and/or regional regulatory requirements for water and food contact use.

Because of technological developments related to the products, systems, and/or services described herein, the data and procedures are subject to change without notice. Please consult your Pall representative or visit www.pall.com to verify that this information remains valid.

© Copyright 2011, Pall Corporation. Pall, , and SUPRApak are trademarks of Pall Corporation.

® Indicates a trademark registered in the USA. *Filtration. Separation. Solution.SM* is a service mark of Pall Corporation.