

Recycling of Lithium-Ion-Batteries: Hydrometallurgy Process



PIAPRECYLIBEN

APPLICATION PAPER

Introduction

The outlook for the electric vehicle (EV) recycling market is highly promising, driven by the rapid growth of the EV industry and the increasing focus on sustainability.

With the surge in EV adoption, the demand for recycling EV batteries is set to soar, creating opportunities for the development of advanced recycling technologies and processes. Governments worldwide are implementing regulations to ensure responsible battery disposal, further boosting the market. Additionally, the focus on resource recovery and the extraction of valuable materials from used EV batteries is driving innovation and economic growth. The EV recycling market is poised to play a crucial role in achieving a sustainable and circular economy.

In recent years, new recycling technologies have emerged, revolutionizing the EV battery recycling landscape. These innovative techniques focus on maximizing resource recovery, reducing waste, and minimizing the environmental impact of battery disposal. Advanced processes such as hydrometallurgical, pyrometallurgical & direct recycle methods enable the extraction of valuable materials like lithium, cobalt, nickel, and manganese from used EV batteries.



1. Direct Recycle- the black matter in the cathode is re-processed with additional infused lithium materials and heated to reactivate the battery chemistry. This method requires the least amount of re-working of the used battery materials.
2. Pyrometallurgy – the battery materials are heated to a high temperature in a smelter operation that leaves only the metal products Cobalt, Nickel, and Manganese as a remaining slag to be further processed and separated

3. Hydrometallurgy: This is a chemical process to get back to the original state of the raw materials and involves dissolving the metals in a strong acid to first separate them from the insoluble materials. Then there are a few different ways to recover the metals (Cobalt, Nickel, Manganese and Lithium) from the acid solution including chemical precipitation, solvent extraction, and selective ion adsorbent beds.

Hydrometallurgy Process to Recycle Lithium-Ion-Batteries

After the batteries have completed their useful service life, they are sent for recycling. Scrap from Battery production is also a source of materials for recycling. The process for Lithium-Ion-Battery recycling using hydrometallurgy is illustrated in Figure 1. Three potential process paths are included: chemical precipitation, solvent extraction, and adsorbent beds. For actual recycle plants there will typically not be a need for all three paths but there may be a one type or a mix of these three technologies. Additional steps to concentrate the streams and further purification steps are not provided in this simplified figure.

The first step in the process is to shred the used batteries and mechanically separate the black mass from structural and other components including the casing, separator membrane and metal foil electrode components.

Next, the black mass is extracted with sulfuric acid to dissolve the valuable metals including Cobalt, Nickel, Manganese and Lithium. Here a bulk filtration step is required to separate the insoluble graphite materials from the acid solution containing the metals. Then the acid solution is treated by one of three methods to recover the metals for re-use. In the precipitation method, the pH is adjusted with caustic until the different metals are precipitated out and then collected by a bulk filtration step. The last step has Lithium crystallized from solution by sodium carbonate to form Lithium Carbonate solids.

For solvent extraction, an ion specific chelating agent is used in an organic solvent to remove the metals from the aqueous solution using an extractor. Liquid-liquid coalescers are used downstream of the extractor to

prevent carryover of any emulsions into downstream processes and to recover the valuable solvent. Not shown in this figure is the separate step to elute off the metals from the extracted solvent typically by using an acid solution and any further concentration and crystallization of the final products.

For adsorbent beds, specialty chemistry applied to granular solids or resin beads is used to remove the specified metals from the aqueous feed stream in different unit operations. Filtration is used to protect the beds from fouling by any solid contaminants in the incoming stream. After the metals are separated onto the adsorbent beds, they are eluted off in a separate step typically by using an acid solution. Not shown is any further concentration steps and crystallization of the final products.

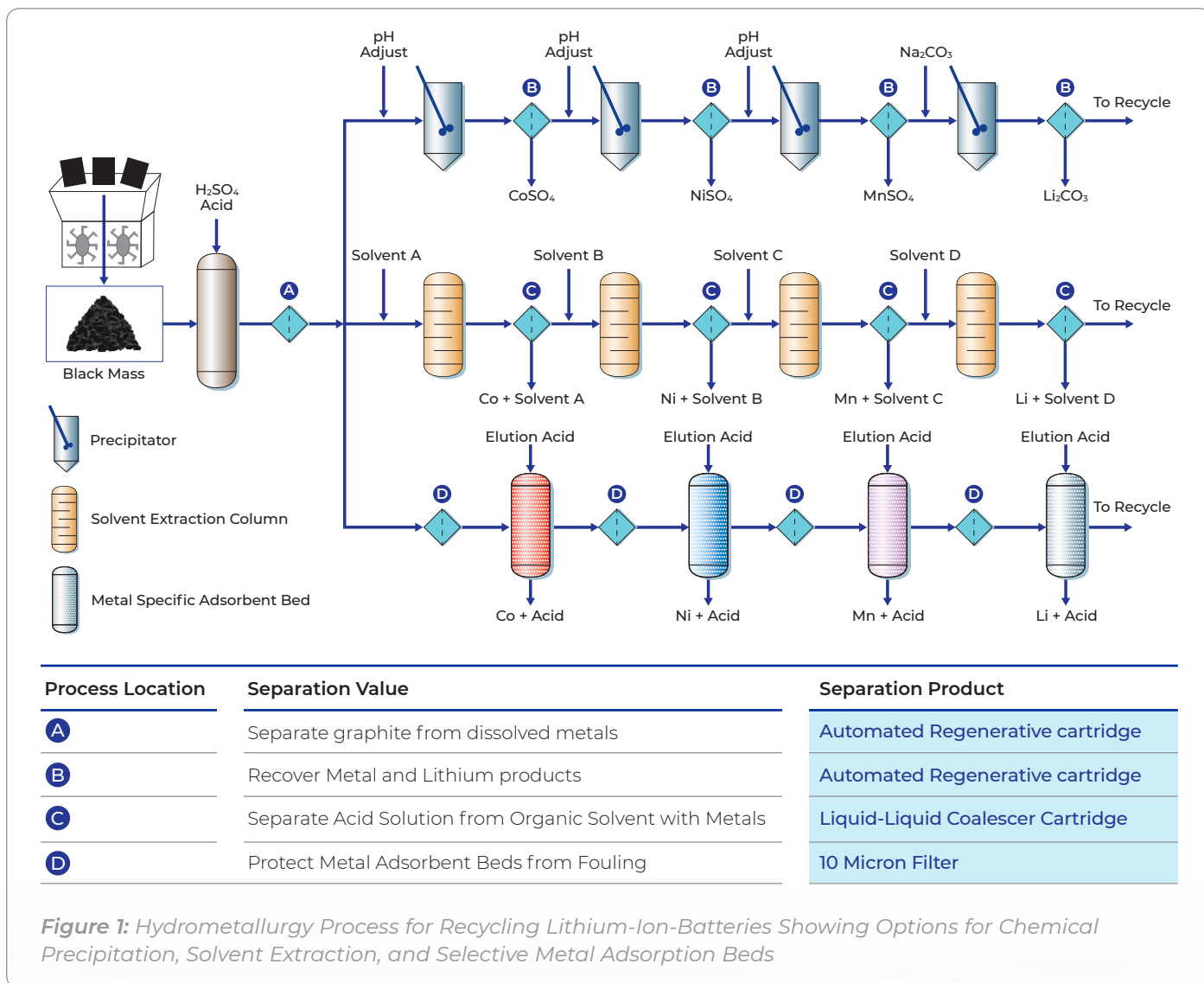

Figure 1: Hydrometallurgy Process for Recycling Lithium-Ion-Batteries Showing Options for Chemical Precipitation, Solvent Extraction, and Selective Metal Adsorption Beds

EV Battery Value Chain

The various stages in the Electric Battery (EV) value chain are given in Figure 2. For each segment, filtration and separation play a vital role in meeting process goals for yield, purity, and reliability. For base materials, mining and unique material processing are required for Nickel, Cobalt and Manganese as well as Lithium as described in this paper. Active materials involve treating of chemicals, specialty chemicals and polymers to make the essential battery components consisting of the separator, electrolyte, and anode/cathode. The battery cells also use chemicals and specialty chemicals

that must be at rigorous purity levels for preparing the casing, filling operations, and preparing slurries.

Pall Corporation is your partner for filtration and separation needs and has experience throughout the EV battery value chain. Pall has over 400 qualified Engineers and Scientists that can provide: prototype testing, on site pilot testing, best practice training, process optimization, audits, contaminant analysis, application troubleshooting, validation services, presentations at scientific forums, and journal publications.

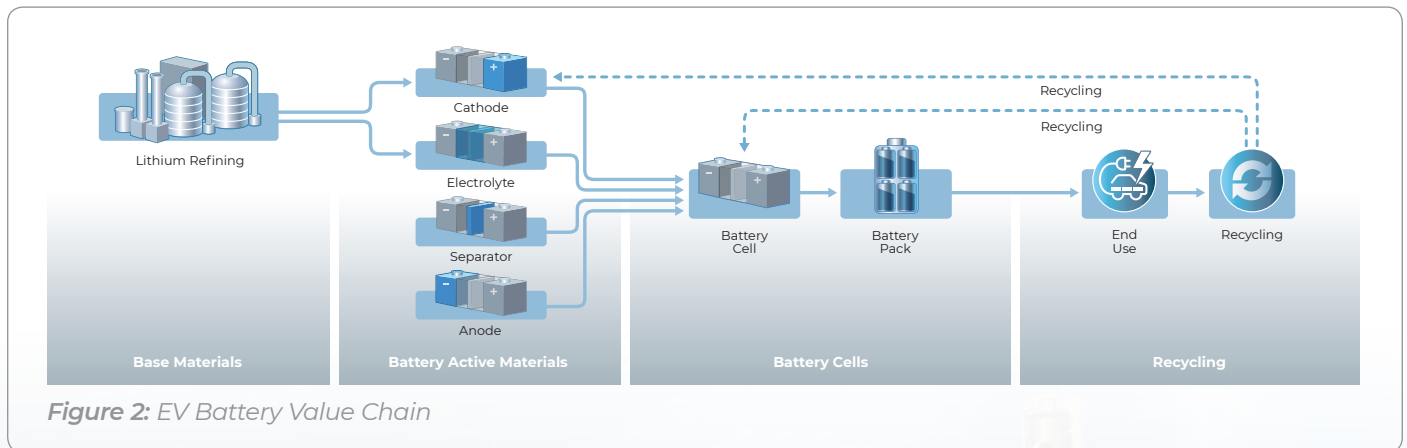

Figure 2: EV Battery Value Chain

Dr. Thomas H. Wines is a Director at Pall Corporation's Application Development Team with over 35 years' experience in Separation Technologies. He is focused on the Energy Market including Lithium-Ion Batteries, Upstream and Midstream Oil & Gas Processes, and Downstream Refining Operations. For more information, Dr. Wines can be reached by email at tom_wines@pall.com.



PALL CORPORATION

Corporate Headquarters
Port Washington, NY, USA
+1-800-717-7255 toll free (USA)
+1-516-484-5400 phone

European Headquarters
Fribourg, Switzerland
+41 (0)26 350 53 00 phone

Asia-Pacific Headquarters
Singapore
+65 6389 6500 phone

Visit us on the Web at www.pall.com/industry
Contact us at www.pall.com/contact

Pall Corporation has offices and plants throughout the world. To locate the Pall office or distributor nearest you, visit www.pall.com/contact.

The information provided in this literature was reviewed for accuracy at the time of publication. Product data may be subject to change without notice. For current information consult your local Pall distributor or contact Pall directly.

IF APPLICABLE Please contact Pall Corporation to verify that the product conforms to your national legislation and/or regional regulatory requirements for water and food contact use.

© Copyright 2024, Pall Corporation. Pall and  are trademarks of Pall Corporation. ® Indicates a trademark registered in the USA.

PIAPRECYLIBEN
June 2024